

POSITIONING HIPSHOT STRING BENDING SYSTEM USING BLADE & PHILLIPS SCREWDRIVER

B-BENDER, E-D TOGGLE'S, & A-G TOGGLE

HIPSHOT PRODUCTS, INC.

8248 State Route 96, Interlaken, NY 14847

www.hipshotproducts.com

Email: hipshot@hipshotproducts.com

Phone: (607) 532-9404

Fax: (607) 532-9530

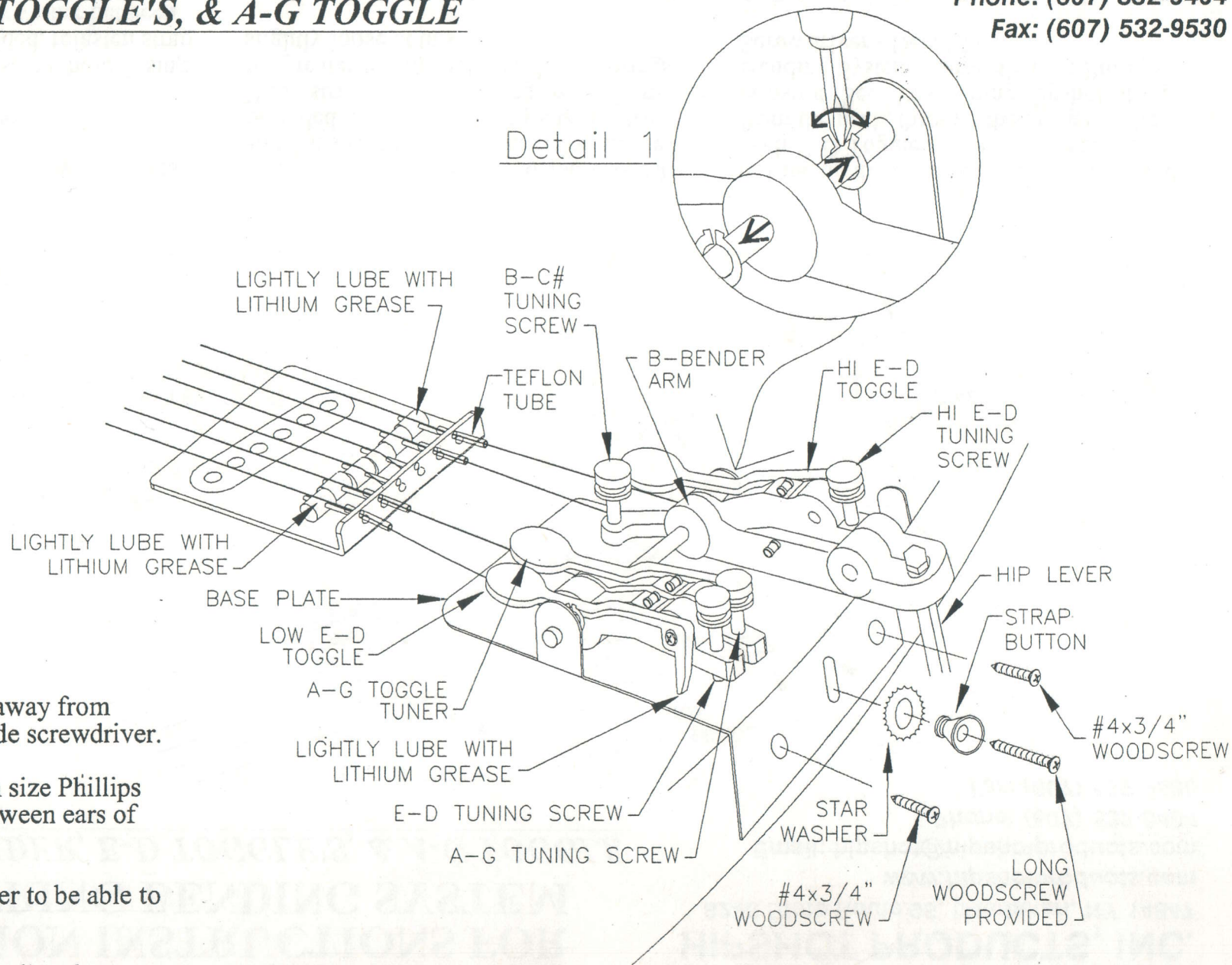

1. Carefully pry snap ring away from raising arm with small blade screwdriver.
2. Carefully insert medium size Phillips screwdriver diagonally between ears of snap ring.
3. Spread snap ring diameter to be able to slide and position arms.

Note: Rings should slide easily when correct size Phillips screwdriver is used